

**Gas Discharge Tube  
Features**

- Small Size Design 4.2×5.0×5.0mm Current
- Handling Capability 5,000A @ 8/20μs
- Low Capacitance and Insertion Loss
- Fast Response and Long Service Life
- Moisture sensitivity level: Level 1

**Exterior**

**SMD**
**Application information**

- AC Power

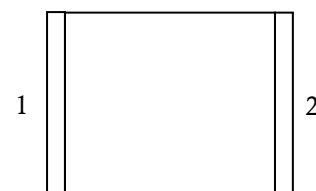
**Package (Top View)**

**Agency Approvals**

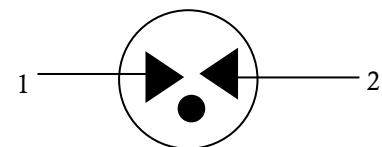
Icon	Description
<b>RoHS</b>	Compliance with 2011/65/EU
<b>HF</b>	Compliance with IEC61249-2-21:2003
	Mean lead free
<b>UL</b>	Compliance with UL1449, Certificated E337906

**Schematic Symbol**

**Electrical Parameter**

DC Breakdown Voltage 1)2)	100V/s	800-1200	V
Impulse Spark-over Voltage	At 1kV/μs	for 99 % of measured values	≤ 1800
	At 1kV/μs	Typical values of distribution	≤ 1700
Impulse Discharge Current 3)	8/20μs ±5Times	5,000	A
Arc Voltage	At 1A	~15	V
Insulation Resistance	DC=100V	≥1	GΩ
Capacitance at 1MHz	VDC=0.5V	≤1.0	pF
Weight		~0.5	g
Operating And Storage Temperature		-40-125	℃
Marking		Without	

1) At delivery AQL 0.65 level II ISO 2859

2) In ionized mode

3) Terms and waveforms in accordance with ITU-T Rec. K. 12; IEC 61643-21

**Part Numbering System**

BF 102 M

(1) (2) (3)

(1) Bencent Gas Discharge Tube

(2) Series: DC Breakdown Voltage,

 e.g.:  $102=10 \times 10^2=1000V$ 

 (3) Tolerance of DC Breakdown Voltage,  $M=+/-20\%$ ,  
 $N=+/-30\%$ , the Specific tolerance is decided by the table  
 of "Electrical Parameter"

**Product Characteristics**

Lead Material	Copper
Body Material	Ceramics
Terminal Finish	100% Matte-Tin Plated

**Environmental Reliability Characteristics**

Testing items	Technical standards
High Temperature Storage Test	Temperature: $125^{\circ}C$ Time: 2H
Low Temperature Storage Test	Temperature: $-40^{\circ}C$ Time: 2H
Vibration	Frequency: 10-500Hz Amplitude: 0.15mm Time: 45min
Resistance of soldering heat	Temperature: $260 \pm 5^{\circ}C$ Time of dip soldering: 10s, 1time

Note: Up-screen program can be specified by customer's request via contacting Bencent service

**Solderability test**

Solderability	Solder Pot Temperature:	$245^{\circ}C \pm 5^{\circ}C$
	Solder Dwell Time:	4-6 seconds

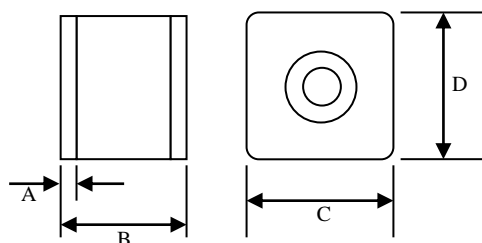
**Product Dimensions**

REF	mm	inch
A	$0.5 \pm 0.1$	$0.020 \pm 0.004$
B	$4.2 \pm 0.3$	$0.165 \pm 0.012$
C	$5.0 \pm 0.2$	$0.197 \pm 0.008$
D	$5.0 \pm 0.2$	$0.197 \pm 0.008$

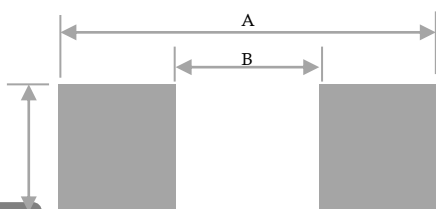
**Recommended Soldering Pad**

REF	mm	inch
A	4.95	0.195
B	3.0	0.118
C	5.5	0.217

**Reflow Profile**

Reflow Condition		Pb-Free assembly
Pre Heat	Temperature Min	150°C
	Temperature Max	200°C
	Time (min to max)	60 – 180 secs
Average ramp up rate (Liquids) T <sub>amp</sub> (T <sub>L</sub> ) to peak		3°C/second max
T <sub>S(max)</sub> to T <sub>L</sub> - Ramp-up Rate		3°C/second max
Reflow	- Temperature (T <sub>L</sub> ) (Liquids)	217°C
	- Temperature (T <sub>L</sub> )	60 – 150 seconds
Peak Temperature (T <sub>P</sub> )		260±0/-5 °C
Time within 5°C of actual peak Temperature (t <sub>p</sub> )		~10 seconds
Ramp-down Rate		6°C/second max
Time 25°C to peak Temperature (T <sub>P</sub> )		8 minutes Max.
Do not exceed		260°C

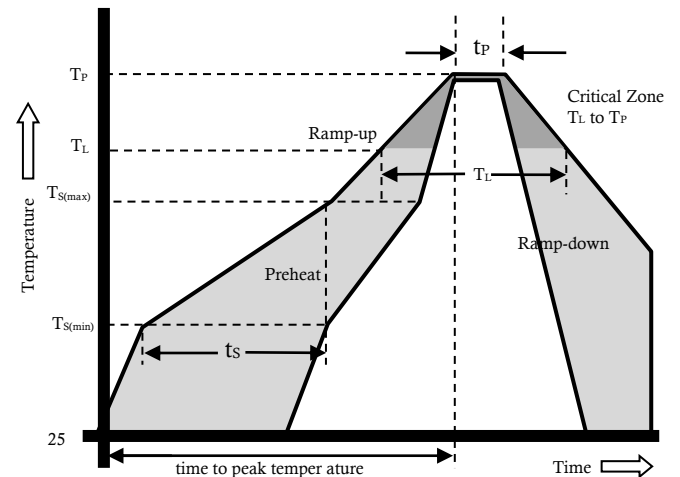
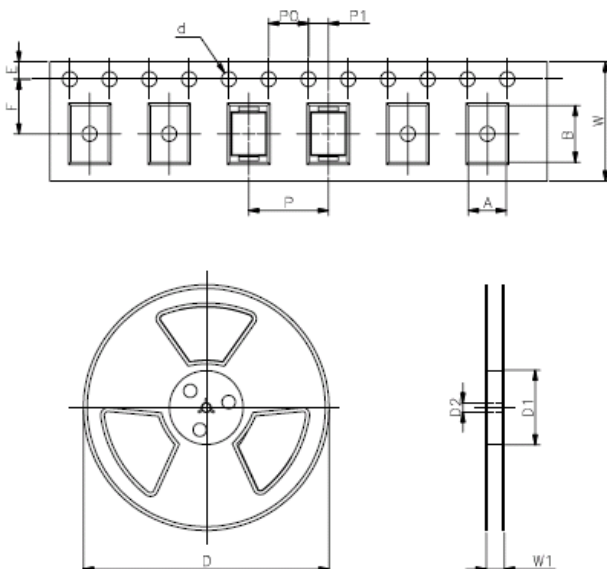
**Package Reel Information**

REF	mm	inch
A	5.5±0.1	0.217±0.004
B	4.7±0.2	0.185±0.008
d	Φ1.5±0.1	Φ0.059±0.004
P0	4.0±0.1	0.157±0.004
P1	2.0±0.1	0.079±0.004
P	12.0±0.1	0.472±0.004
E	1.75±0.1	0.069±0.004
F	7.5±0.1	0.295±0.004
W	16.0±0.3	0.630±0.012
D	Φ330.0	Φ13.0
D1	Φ50Min	Φ1.97Min
D2	Φ13±0.5	0.512±0.020
W1	16.8±2.0	0.661±0.079

Outline	Reel (PCS)	Per Carton (PCS)	Reel Diameter (mm)	Carton Size(mm)		
				L	W	H
TAPING	1,000	16,000	330	360	360	380